

# Meriden Satin Nickel Manual Valve Set (Angled Manual)



Available Finishes	
Brass	Satin Nickel

Connection size	
Valve to Radiators	1/2" BSPT
Valve to Pipe	15 mm Compression

Allen Key size	
To adjust Lock-Shield	SW8
To fit Coupler to Radiator	SW12
Allen Keys are not included	

Pressure Ratings	
Max Test Pressure	16 Bar
Max Operating Pressure	10 Bar
Max Differential Pressure	1 Bar
Pressure Drop Value (Kvs)	N/A m <sup>3</sup> /h
Kvs value is the metric measure for the flow of a fully opened valve. It is defined as: The volume flow in cubic metres per hour of water at a temperature of between 5° and 40° Celsius with a pressure drop across the valve of 1 bar.	

Flow Ratings	
Normal Flow Rate	N/A m <sup>3</sup> /h
Max Flow Rate	2.45 m <sup>3</sup> /h

Temperature Ratings	
Max Test Temperature	100°C
Max Operating Temperature	120°C
Temperature Adjustment Range	N/A

Disclaimer	
All dimensions are approximate and for roughing in only.	
We recommend no work be carried out until the goods arrive.	
We can take no responsibility for errors in information supplied.	

# Meriden Satin Nickel Manual Valve Set (Angled Manual)

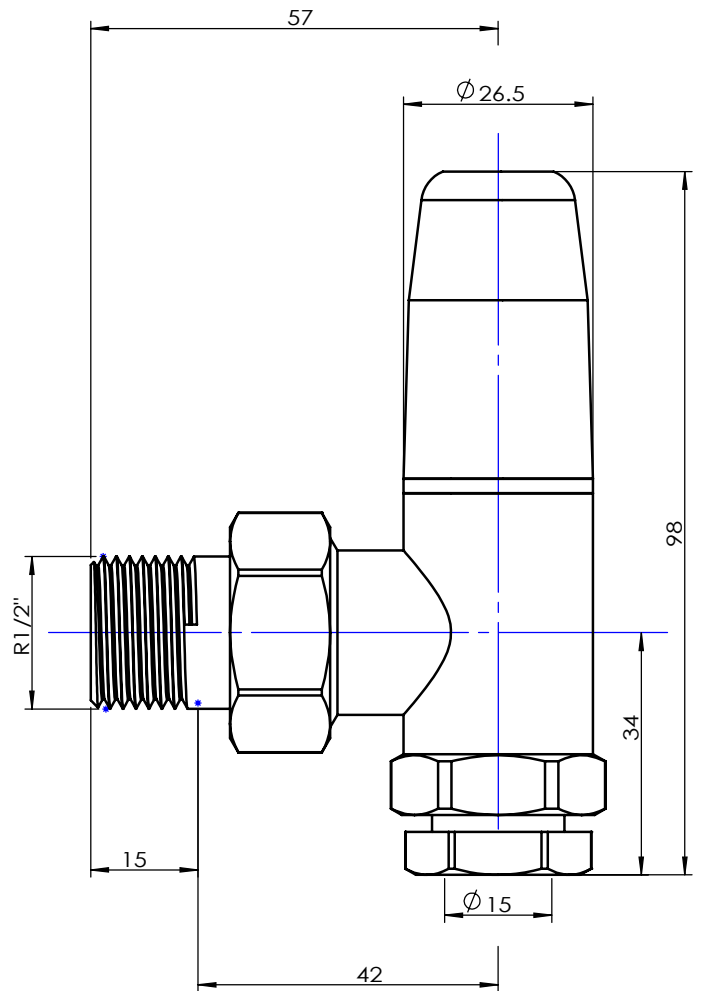
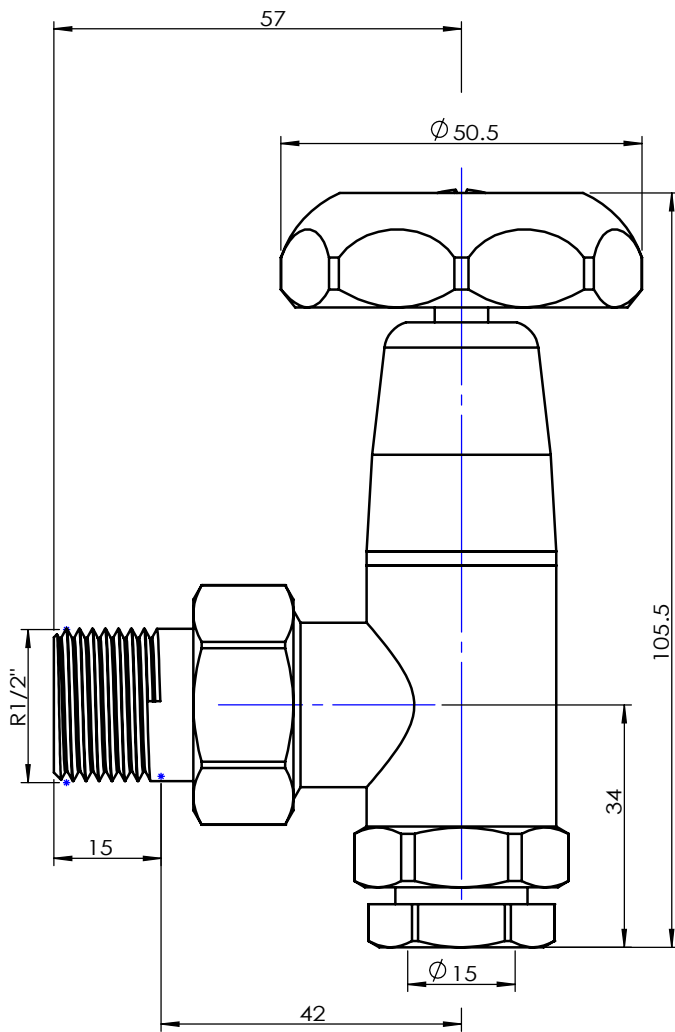

## Manual Valve Installation

Your radiator valves should only be installed by a competent and suitably qualified installer. Your warranty may be void if installation is not carried out by a suitably qualified heating engineer.

All plumbing joints should be sealed using appropriate tools, methods and materials. Never over tighten any joint or coupling.

Ensure care is taken to protect the decorative finish on the valves during installation. We would recommend applying protection (for example, at least two layers of paper between the faces of the nuts and any spanner) to ensure the surfaces are not marked.